

Eurocopter EC145T2

Information Sheets (example)

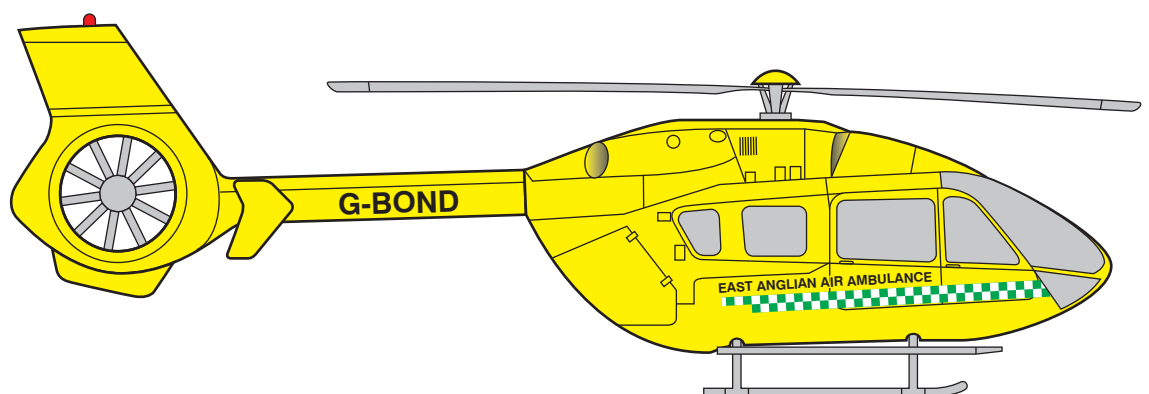

Eurocopter EC145T2

Technical Specification (example)

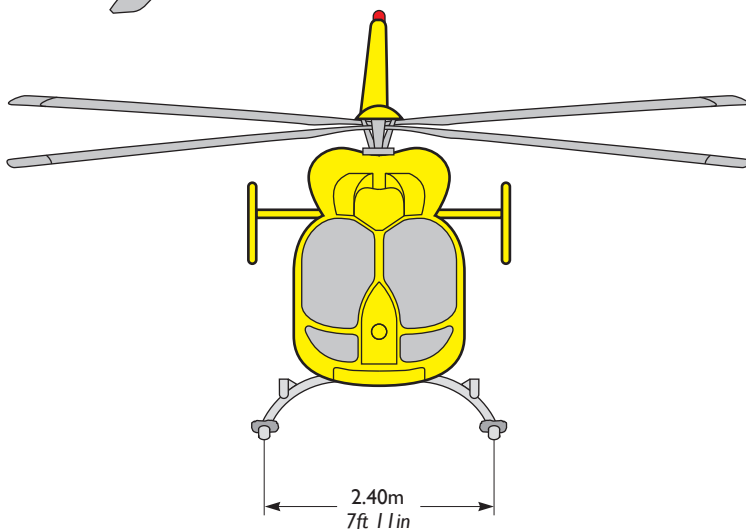
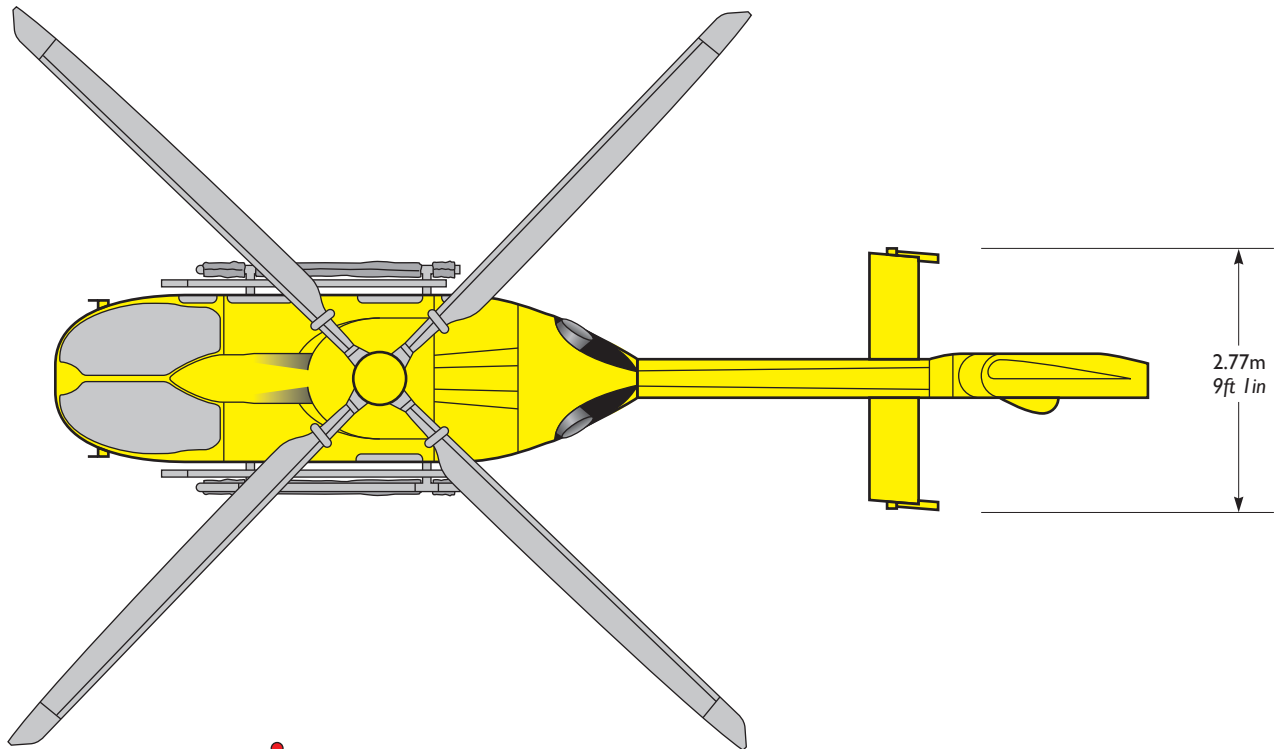
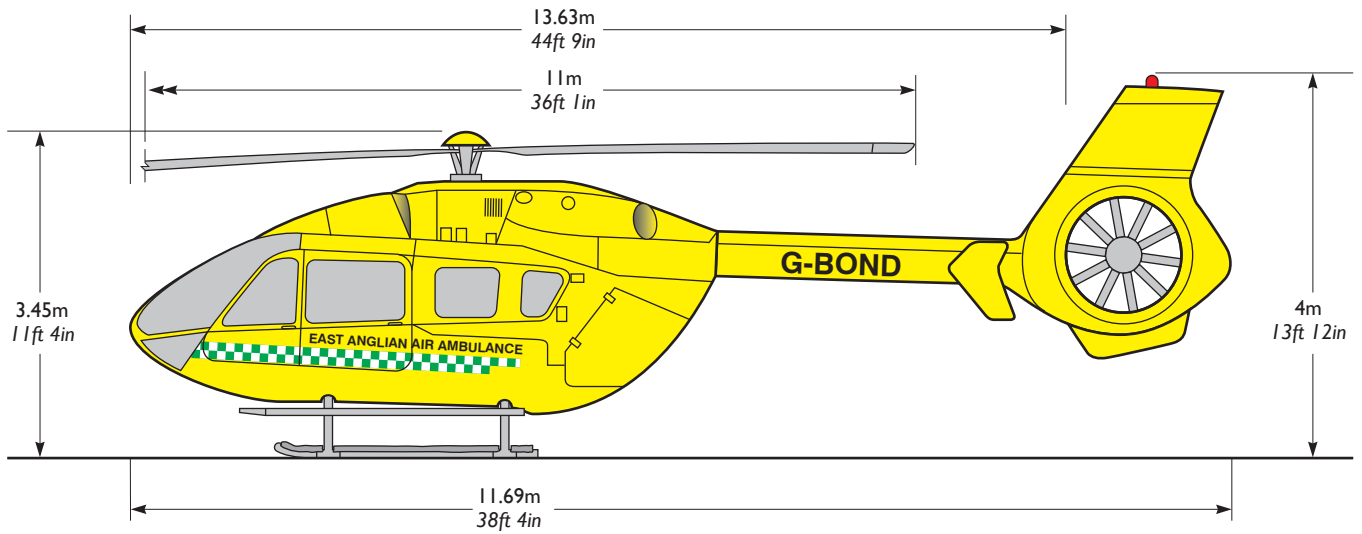

Engine Type	2 x Turbomeca Arriel 2E
Maximum take-off weight (MTOW)	3650kgs
Standard weight (ambulance equipped)	2326kgs
Standard Fuel Tank Capacity	738kgs
Fuel consumption Average	260kg/hr
Fast cruise speed	145kts
Normal Cruise Speed	135kts
Maximum range standard tanks	355nm
Stretcher capacity	1/2
Medical attendant seating	3/4
Maximum hook load	1500kgs
Maximum seating capacity	12 (incl pilot)
Rotor max engage/stop	50kts

Above performance based on 1000ft ASL, ISA, still air conditions including VFR reserves.

Eurocopter EC145T2

Seating/Stretcher/Incubator Layouts (example)

Configuration A
4 attendant | 1 patient

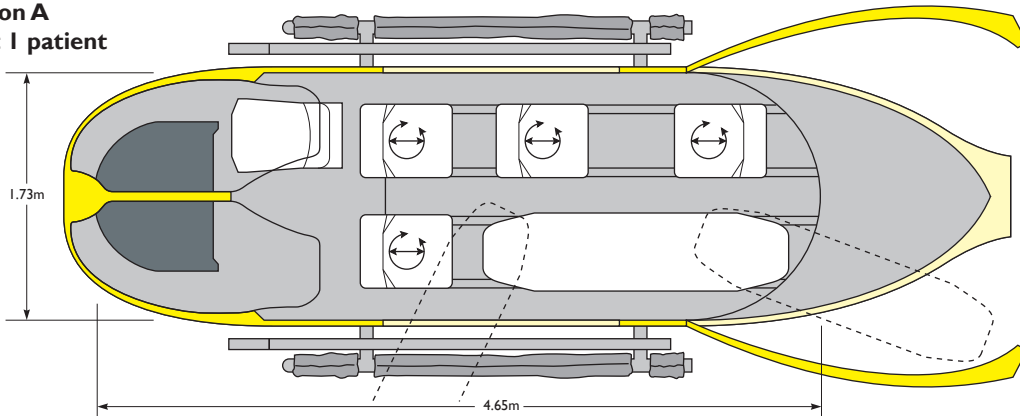

Configuration B
4 attendant | 1 patient

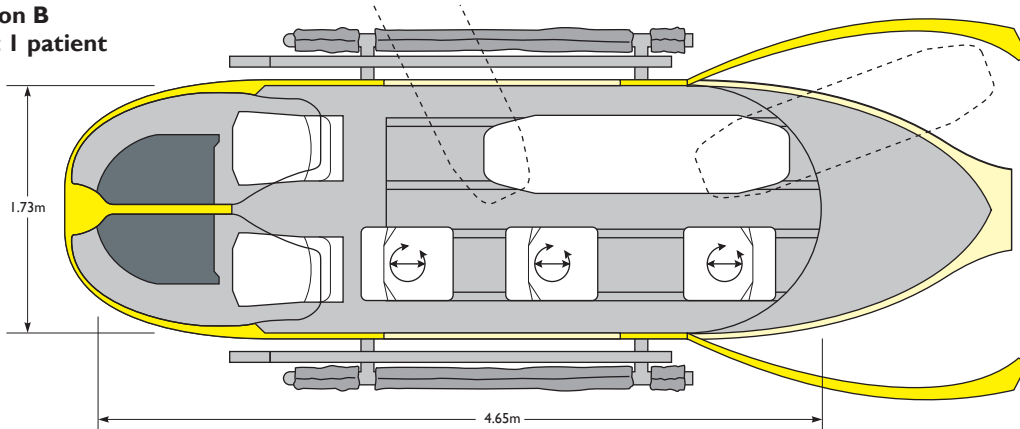

Configuration C
5 attendant | 1 patient

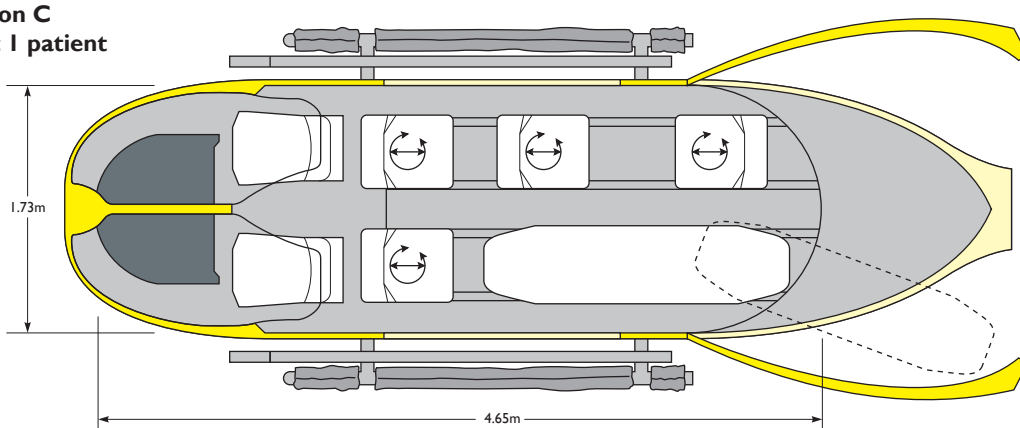

Configuration D
4 attendant | 1 incubator

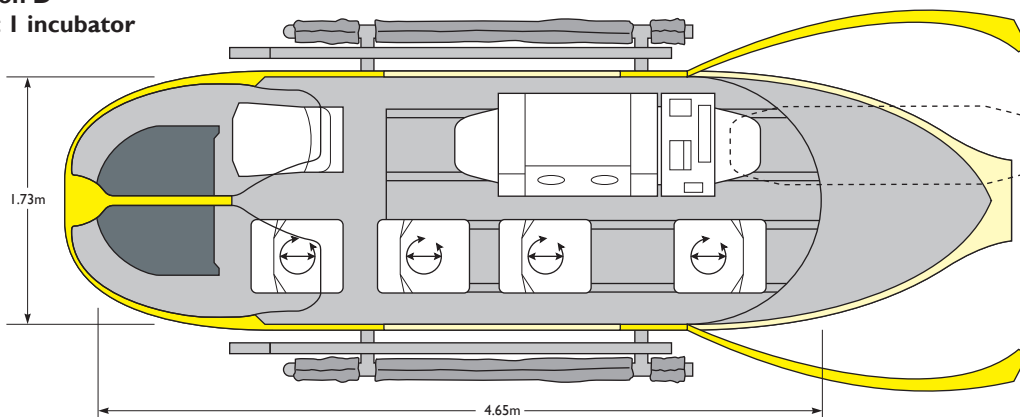

Eurocopter EC145T2

Seating/Stretcher/Incubator Layouts (example)

Configuration E
2 attendant 2 patient

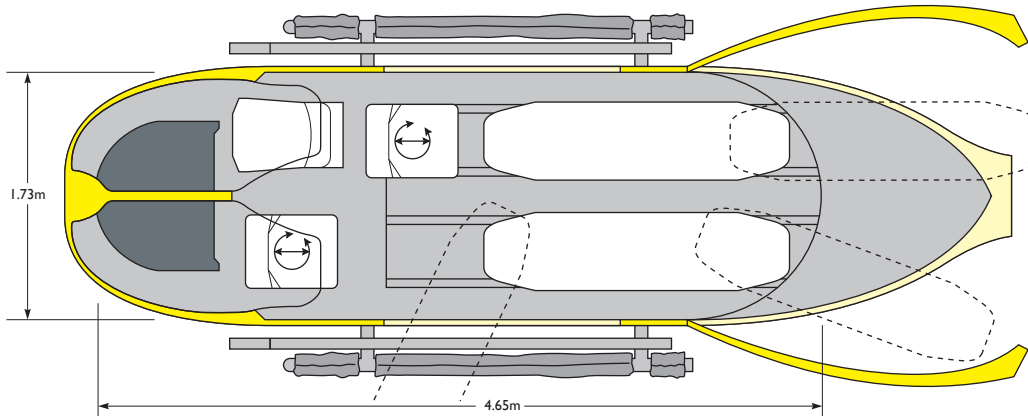

Configuration F
3 attendant 1 patient

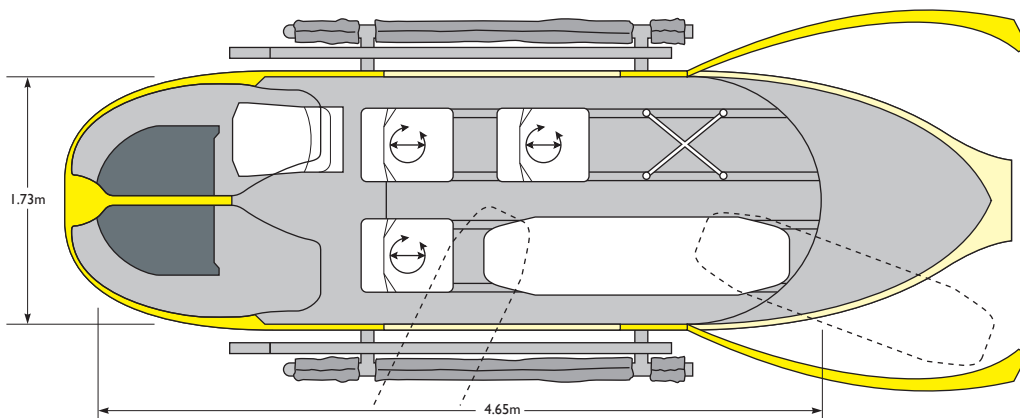

Configuration G
2 attendant 1 maternity

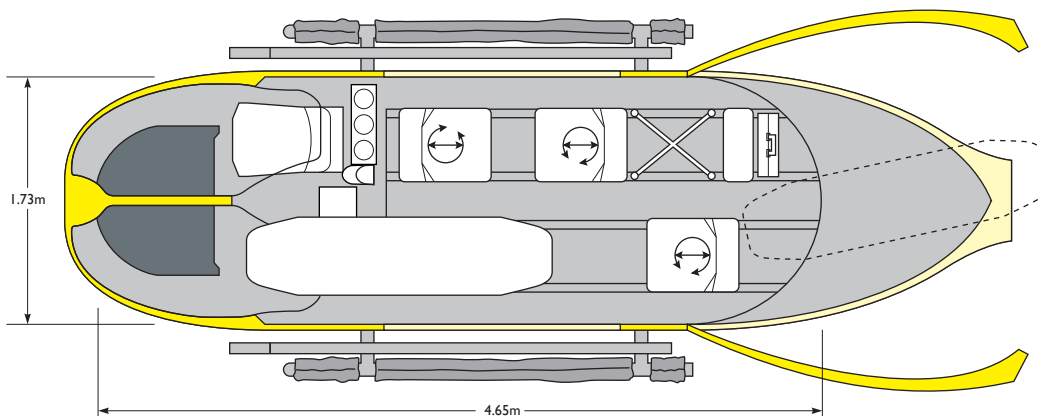

Eurocopter EC145T2

Specification (example)

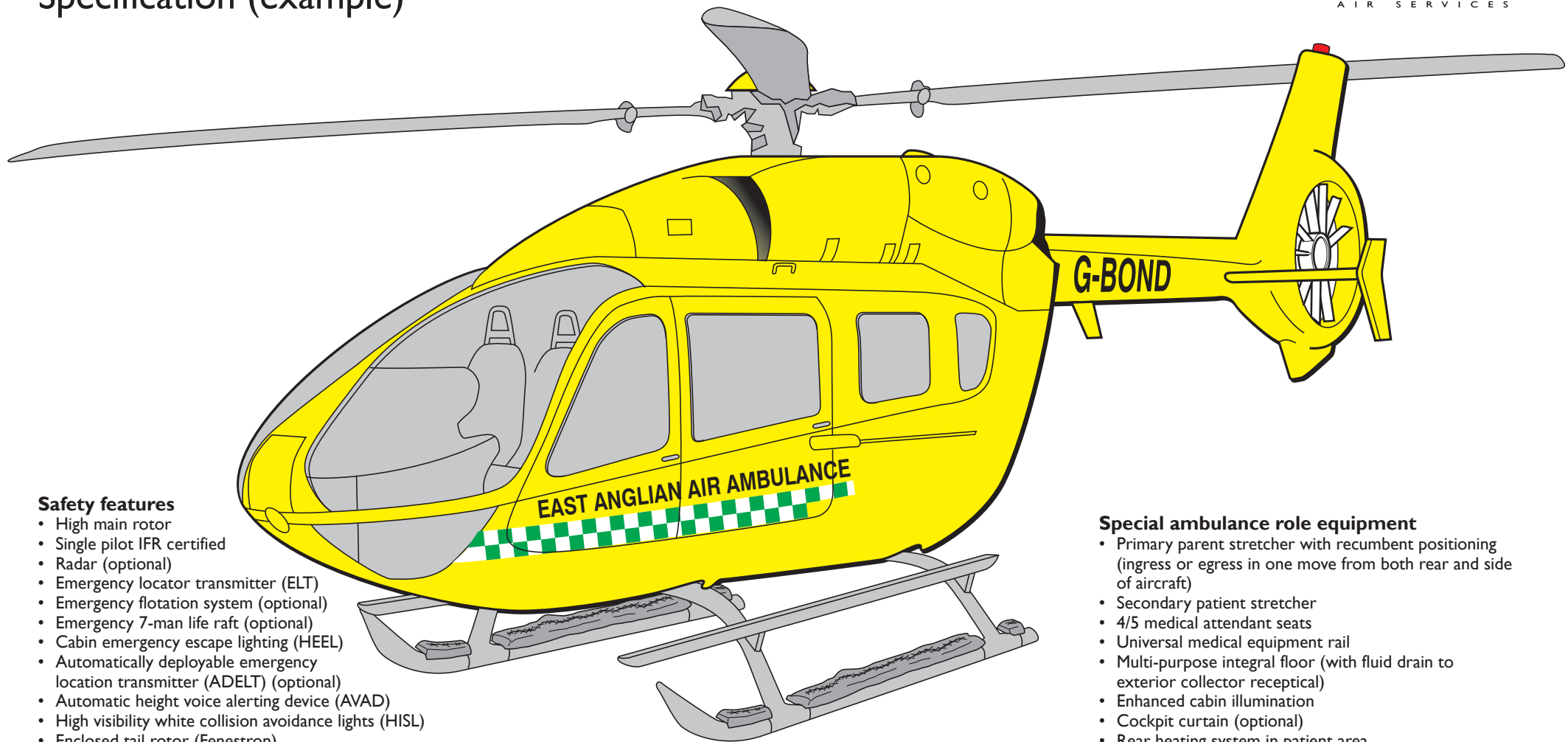

Safety features

- High main rotor
- Single pilot IFR certified
- Radar (optional)
- Emergency locator transmitter (ELT)
- Emergency flotation system (optional)
- Emergency 7-man life raft (optional)
- Cabin emergency escape lighting (HEEL)
- Automatically deployable emergency location transmitter (ADELT) (optional)
- Automatic height voice alerting device (AVAD)
- High visibility white collision avoidance lights (HISL)
- Enclosed tail rotor (Fenestron)
- Crashworthy fuselage design
- Sonic locator beacon
- 2 search and rescue beacons (SARBEs)
- Cockpit voice / flight data recorder (CVFDR)
- Usage monitoring system (UMS) (optional)
- Traffic collision avoidance system (TCAS) (optional)
- Enhanced ground proximity warning system (EGPWS) (optional)
- Wire strike protection (WSPS) (optional)
- Live wire detection system (LWDS) (optional)

General features

- 4 cabin doors (2 side sliding doors)
- 2 rear clamshell doors
- 1300kg cargo hook (optional)
- Auxiliary fuel tank (optional)
- 2 landing lights (one moveable)
- Rescue hoist (optional)

Special ambulance role equipment

- Primary patient stretcher with recumbent positioning (ingress or egress in one move from both rear and side of aircraft)
- Secondary patient stretcher
- 4/5 medical attendant seats
- Universal medical equipment rail
- Multi-purpose integral floor (with fluid drain to exterior collector receptacle)
- Enhanced cabin illumination
- Cockpit curtain (optional)
- Rear heating system in patient area
- Emergency services communication system
- Dedicated ambulance crew/patient intercom system
- Incubator certified
- Nitesun (optional)
- NVG (optional)
- Skyshout (optional)
- Medical gases delivery system
- Power outlet panels for medical equipment supply
- Maternity Stretcher Installation